

Technical Properties

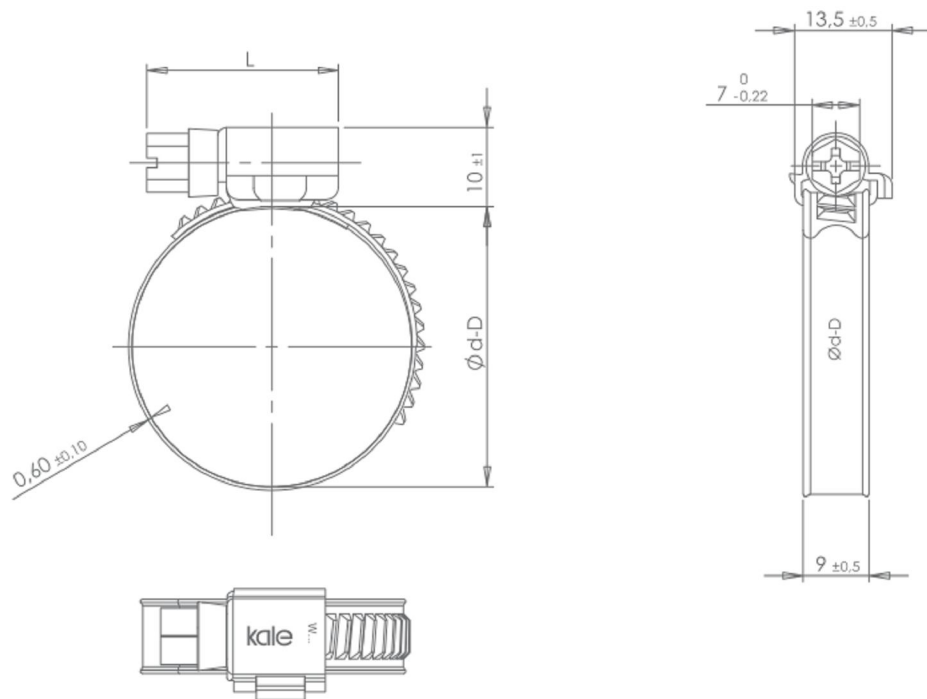

Ø d - D (mm)	W1 - W2 - W3 - W4 - W5 (Nm)		L (mm) ± 2
	AD max	PD max	
8-16	2,5	3,5	20
12-20	2,5	3,5	20
12-22	3,0	4,0	24
16-25	3,0	4,0	24
16-27	3,0	4,0	24
20-32	3,0	4,0	24
23-35	3,0	4,0	24
25-40	3,0	4,5	24
30-45	3,0	4,5	24
32-50	3,0	4,5	24
40-60	3,0	4,5	24
50-70	3,0	4,5	24
60-80	3,0	4,5	24
70-90	3,0	4,5	24
80-100	3,0	4,5	24
90-110	3,0	4,5	24
100-120	3,0	4,5	24
110-130	3,0	4,5	24
120-140	3,0	4,5	24
130-150	3,0	4,5	24
140-160	3,0	4,5	24
...
380-400	3,0	4,5	24

Screw Head	Philips Type	Slotted
W1	●	
W2	●	
W3		●
W4		●
W5		●

Material Code	Housing	Screw	Band
W1	Mild steel	Mild steel	Mild steel
W2	1.4016 DIN EN-10088-2 or equivalent	Mild steel	1.4016 DIN EN-10088-2 or equivalent
W3	1.4016 DIN EN-10088-2 or equivalent	1.4016 DIN EN-10088-3 or equivalent	1.4016 DIN EN-10088-2 or equivalent
W4	1.4301 DIN EN-10088-2 or equivalent	1.4301 DIN EN-10088-3 or equivalent	1.4301 DIN EN-10088-2 or equivalent
W5	1.4401 DIN EN-10088-2 or equivalent	1.4401 DIN EN-10088-3 or equivalent	1.4401 DIN EN-10088-2 or equivalent

AD: Recommended tightening torque
PD: Testing torque